

# PureLink

## Owner's Manual HTX-8800-II

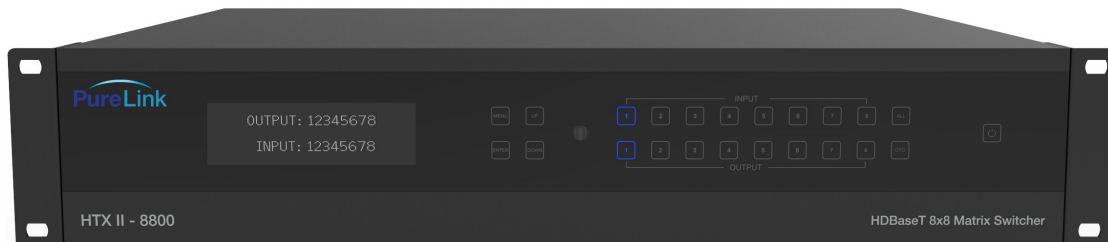

Ultra HD/4K 8x8 HDMI to HDBaseT Matrix Switcher  
with POE and HDCP 2.2

**PureLink™**  
535 East Crescent Avenue  
Ramsey, NJ 07446  
USA  
Tel: +1.201.488.3232  
Fax: +1.201.621.6118  
E-mail: [sales@purelinkav.com](mailto:sales@purelinkav.com)  
[www.purelinkav.com](http://www.purelinkav.com)

For order support, please contact your local dealer.  
For technical support, please contact us at [support@purelinkav.com](mailto:support@purelinkav.com)

# TABLE OF CONTENTS

## Chapter 1. Product Overview, Operation & Specification

1.1 Safety Precautions	-----	3
1.2 Declaration of Conformity	-----	4
1.3 What's in the Box	-----	4
1.4 Product Introduction	-----	5
1.5 Front View	-----	5
1.6 Front Panel Button Operation	-----	6
1.7 Rear View	-----	8
1.8 HTX-Rx	-----	8
1.9 Product Specification	-----	11
1.10 IR Remote Control	-----	13
1.11 IR Control	-----	14
1.12 Cable Termination	-----	16
1.13 Installation Guidelines	-----	19
1.14 Communication Settings	-----	19

## Chapter 2. Communication Code Configuration

2.1 Control Programmer's Guide	-----	21
2.2 Overview	-----	21
2.3 Command Code Formats	-----	21
2.4 General Rules for Command Codes	-----	22
2.5 Command Ack Value Response	-----	23
2.6 Connecting Switches	-----	24
2.7 Disconnecting Switches	-----	25
2.8 Connection Status Check	-----	27

## Chapter 3. Additional Information

3.1 Manufacturer's Warranty (3-Year)	-----	28
3.2 Customer Service	-----	28

## Chapter 1. Introduction

### 1.1 Safety Precautions

- All safety instructions should be read and understood before the unit is operated.
- The owner's manual and safety instructions should be retained for future reference.
- Unplug this unit from the wall outlet before cleaning. Do not use liquid or aerosol cleaners. Use a damp cloth only.
- Keep away from wet, magnetic, and flammable surfaces or substances.
- Always use the correct power supply (indicated on the product label) when operating this unit.
- This unit may be equipped with a 3 wire grounding-type plug - a plug having a third (grounding) pin. This pin will only fit in to a grounding type power outlet. If you are unable to insert the plug in to the outlet, contact your electrician to replace your obsolete outlet.
- Air vents should be kept clean and unobstructed at all times.
- Please refrain from using frayed power cords and damaged wall outlets.
- Do not place any heavy objects or equipment on top of the unit.

**If you experience any malfunctioning of product or have any question as to operation of the product, please contact our customer service center.**

**PureLink™**

Tel: 201.488.3232

Email: [support@purelinkav.com](mailto:support@purelinkav.com)

## 1.2 Declaration of Conformity

According to Council Directive 73/23/EEC (February 19, 1973) on the Harmonization of the Laws of Member States relating to Electrical Equipment; Council Directive 89/336/EEC (May 3, 1989) on Electromagnetic Compatibility; Council Directive 93/68/EEC (July 22, 1993)-Amending Directives 89/336/EEC (MC) and 73/23/EEC (Low Voltage Equipment Safety), and/or CPU Boards and Power Supplies used Council Directive 93/68/EEC with Matrix, Dtrovision LLC, 535 E Crescent Ave Ramsey, NJ 07446 201-488-3232, declares under sole responsibility, that the product identifies with 93/66/EEC of the Council Directive Low Voltage Equipment Safety. Each product marketed is identical to the representative unit tested and found to be compliant with the standards.

## 1.3 What's in the Box

- 1 x HDBaseT™ 8x8 Matrix Switcher
- 9 x Wideband IR Blaster cable
- 10 x Wideband IR Receiver cable
- 1 x Matrix Remote Controller
- 1 x AC Power cable
- 1 x RS-232 cable
- 1 x Operation Manual

## 1.4 Product Introduction

The new **HTX-8800 II Ultra HD/4K HDMI to HDBaseT outs with POE and HDCP 2.2** provides switching for up to eight (8) HDMI to any eight (6) HDBaseT outputs and 2 HDMI outputs. PureLink's legendary EDID/HDCP Management System, consistently praised by system integrators as the most reliable in the industry. Together with full HDCP v 2.2, PureLink's uncompromising design and manufacturing standards, the HTX-8800 II delivers unparalleled quality and value.

### \* Features

- **HDMI 2.0b, HDCP 2.2 and HDCP 1.4 compliant**
- **8 HDMI inputs, 6 HDBaseT™ outputs and 2 independent HDMI outputs**
- **Video resolutions up to 4K@60Hz (4:4:4)**
- **Supports automatic 4K@60Hz (4:4:4) to YUV (4:2:0) conversion for HDBaseT™ outputs**
- **Supports pass-through audio up to 7.1 channels of High Definition audio (LPCM, Dolby TrueHD, and DTS-HD Master Audio)**
- **Built-in independent audio matrix with Volume, Mute, and Audio delay for lip-sync adjustment (LPCM only)**
- **HDR, ARC, CEC and smart EDID management supported**
- **Control is via on-panel Button, IR, RS-232, LAN and Web UI**
- **24V POC on all HDBaseT™ ports (48V POE is optional)**
- **2U rack mounted design with aluminum front panel housing**
- **Bundle kits available with receivers**
- **3-year parts and labor warranty, extends to 5-year when used exclusively with PureLink TotalWire™ CATx cable (some restrictions may apply, ask factory for details)**

## 1.5 Front View of HTX-8800-U

The HTX-8800 II chassis is mountable on 19" standard rack with brackets. On front panel, there are some function keys, input-output buttons and a status display window placed as shown in Figure 1-1.

<Front Panel>

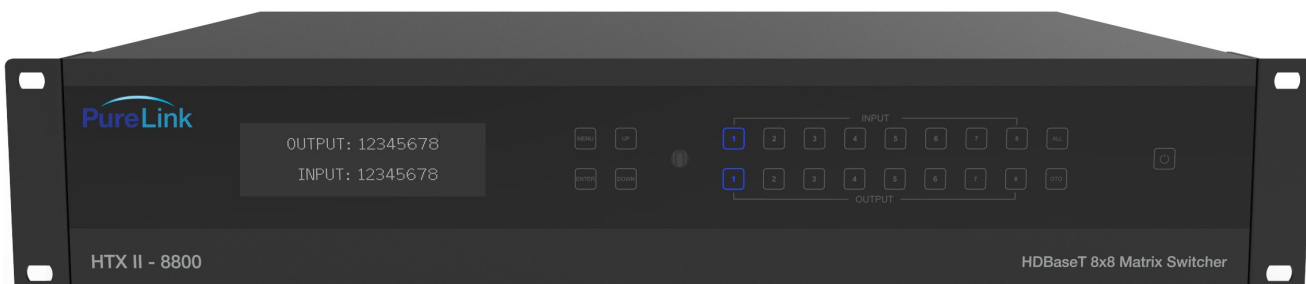

(Figure 1-1)

**POWER:** Main power switch ON / OFF

**DISPLAY:** View menu and system mode

**MENU:** EDID setup menu

**UP:** Up button

**DOWN:** Down button

**ENTER:** Execution button

## 1.6 Front panel button operation

### Creating a switching

- Press Output # button
- Press Input # button
- Switching is completed

### EDID

- Press MENU button
- Use Up and Down buttons to select EDID from the EDID library list
- Press Enter button
- Select input# which you want to save selected EDID to
- Press Enter button

### EDID

HTX II series matrix switcher provides Auto EDID management system; easy and fail safe way to handle EDID, via EDID library system and EDID emulation.

### What's EDID?

**Extended Display Identification Data (EDID)** is an information set that digital display provides to describe its capabilities to a Video source. Video source will know what kinds of displays are connected and it will determine which resolution to Output according to the EDID information received from the display.

The EDID normally includes manufacturer name and serial number, sets of capable resolution including native resolution, supported timing, pixel mapping data (for digital displays only) and etc.

In a digital connectivity environment; in order to support the maximum resolution of connected monitor, EDID handshake is a critical because improper EDID handshake between sources to the display will result in no image on the display.

EDID handshake may sound simple; however, with multiple peripheral devices within the chain, display's EDID information easily get lost or blocked while it is traveling to the source device.

HTX series matrix switcher provides Auto EDID management system to meet today's sophisticated digital connectivity integration environment.

Auto EDID management system

### **EDID library**

15 most widely used EDID data is pre-programmed internal EEPROM chipset which user can take and save onto the any of the matrix switcher's Input EEPROM.

By optimizing factory default EDID and EDID library feature, in most cases, HTX series matrix switcher will work out of the box without any additional configuration.

### **Emulation**

The user can easily save an EDID data from any display devices directly onto the matrix switcher's input port. By saving display device's EDID information on the matrix switcher input port, input port will act as a display to the video source.

**Note) There may be display devices that are not allowing other device to emulate its EDID data.**

**Note) Certain EDID data may not be compatible with some devices, in this case, it is recommended to use scaling option**

## 1.7 Rear View of HTX-8800-U

<Back Panel>

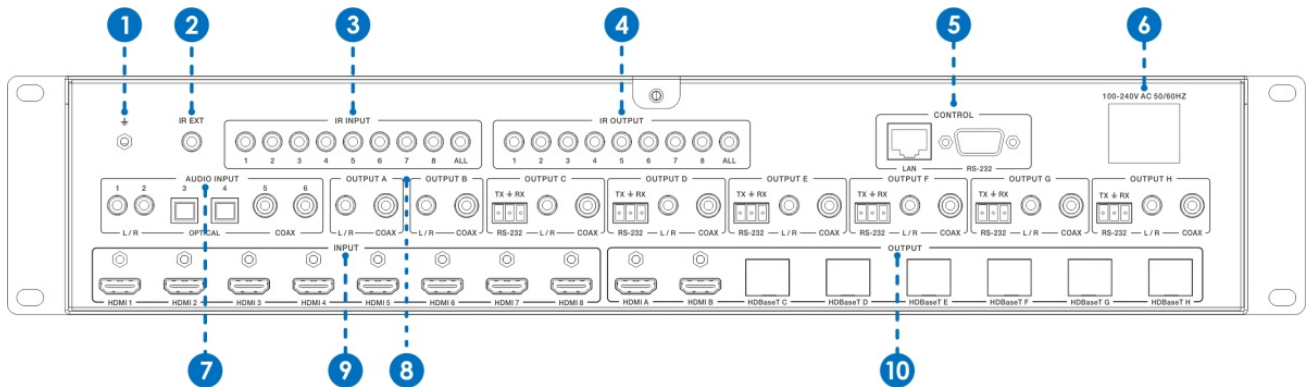

(Figure 1-2)

1. **GND:** Connect the Housing to the ground.
2. **IR EXT:** If the front IR sensor of unit is obstructed or the unit is installed in a closed area out of infrared line of sight, the IR RX receiver included in the package can be inserted to this IR EXT port to extend the IR.
3. **IR INPUT:** Connect to IR Receiver.
4. **IR OUTPUT:** Connect to IR transmitter.  
**NOTE:** IR INPUT and IR OUTPUT are Super IR control system interfaces. For further details, please refer to the Super IR system control introduction.
5. **PC CONTROL:**  
**LAN:** This port is the link for TCP/IP control and connects to an active Ethernet link by an RJ-45 cable.  
**RS-232:** Connect to a PC or control system by D-Sub 9-pin cable to control the matrix with RS-232 commands.
6. **AC POWER:** Connect to AC power through an AC power cable.
7. **AUDIO INPUT:** Connect to the external audio source devices.
8. **AUDIO OUTPUT:** The coaxial and L/R audio output to audio amplifiers or speakers.
9. **HDMI INPUT:** Connect to the HDMI source devices such as a DVD player or Set-top Box through a HDMI cable.
10. **2 HDMI OUTPUT and 6 HDBaseT™ OUTPUT:** The HDMI outputs connect to TVs or monitors and the HDBT outputs connect to the HDBT Receivers.

## 1.8 HTX II-Rx

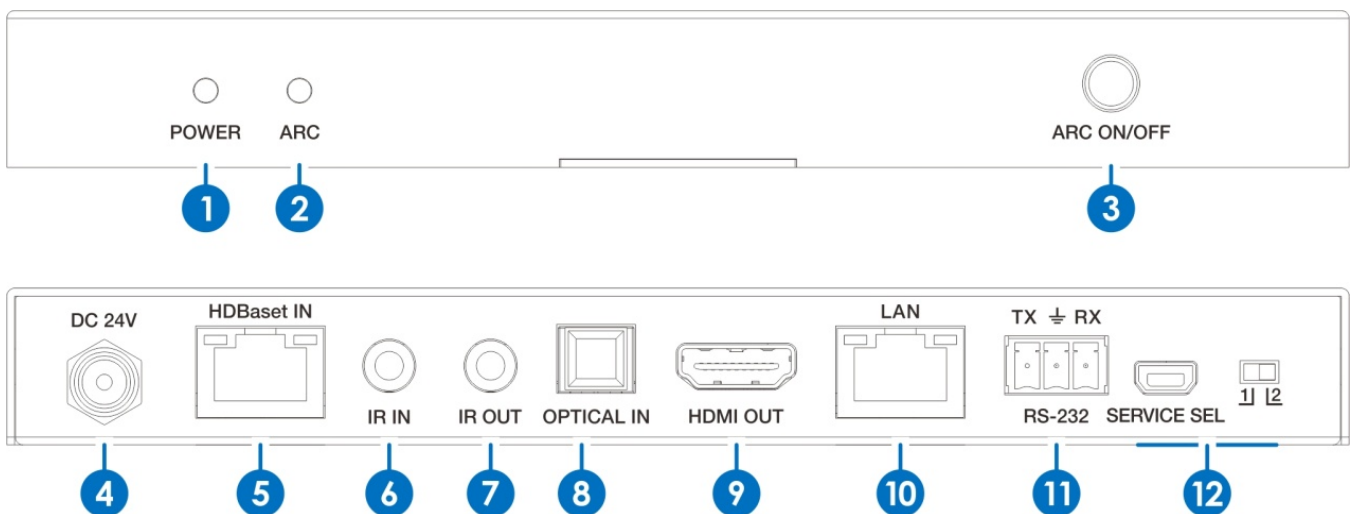



1. **POWER LED:** System power indicator.
2. **ARC LED:** ARC status indicator.
3. **ARC Button:** ARC function on/off.  
**Enable ARC:** LED ON  
**Disable ARC:** LED OFF
4. **DC 24V:** Connects 24V/1A adaptor to AC wall outlet for power supply.  
(Don't need this power supply if connecting to POC supported Matrix)
5. **HD BaseT IN:** Connects to Matrix with a Cat5e/6/7 cable.
6. **IR IN:** Connect to IR Receiver.
7. **IR OUT:** Connect to IR transmitter.
8. **OPTICAL IN:** Connects to audio source device such as DVD or Blue-ray player for sending audio signal to Matrix.
9. **HDMI OUT:** Connects to a HDMI display device.
10. **LAN:** Connects to an active network for LAN sharing of a total transmission rate up to 100Mbps. Or when a compatible LAN equipped Matrix is connected to an active network, this allows the network access (including internet access if available) to be shared between the Matrix and Receiver.  
**Note:** Do not connect this RJ45 port to any of the HDBaseT™ port.  
**Such behavior may damage this port or whole device.**
11. **RS-232:** Connect to any devices with RS-232 port for RS-232 commands transmission.
12. **SERVICE SEL 1/2:** Reserved for manufacturer use only.

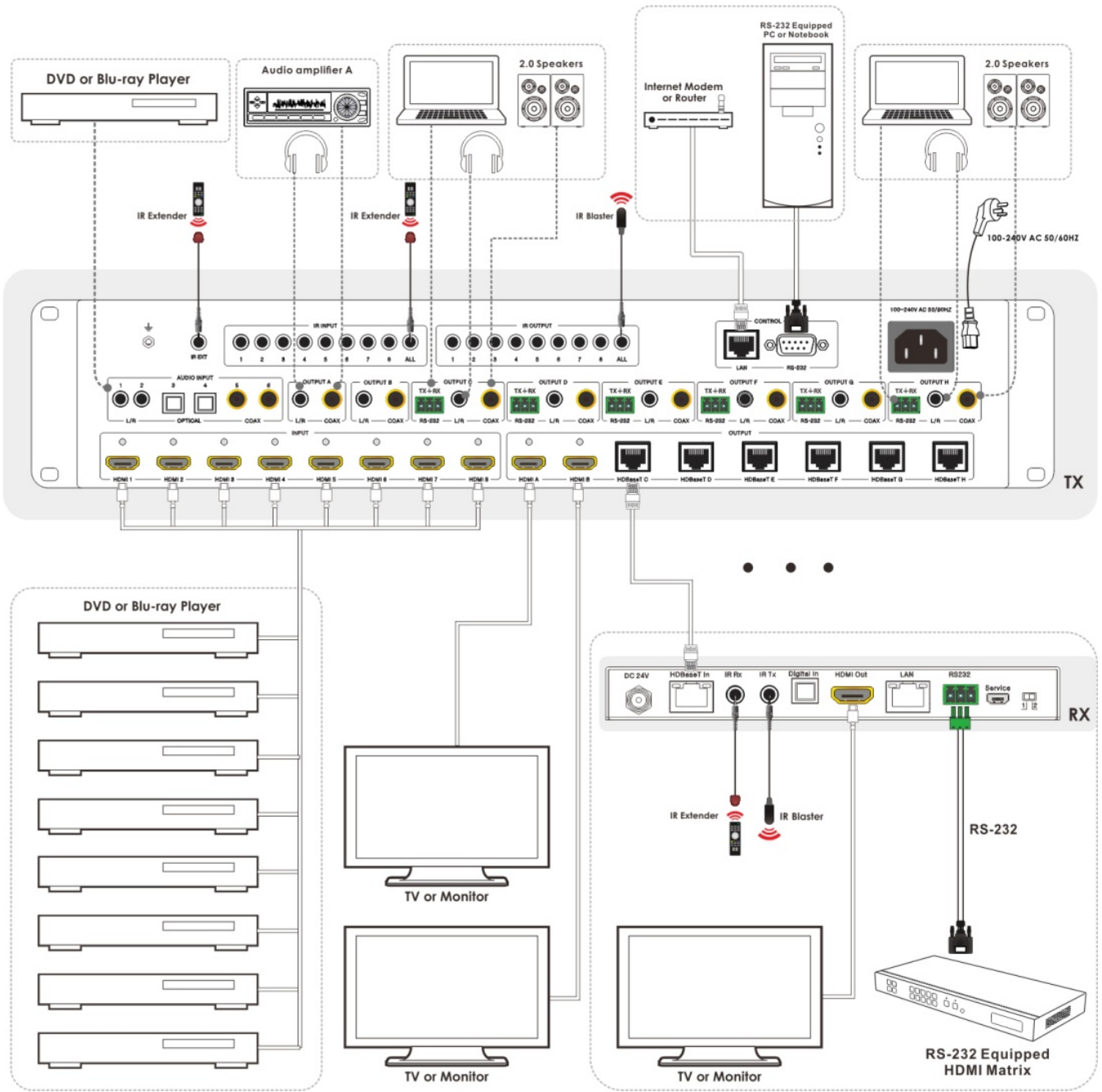

<Application diagram>

## 1.9 Product Specifications

Technical	
<b>HDMI Compliance</b>	HDMI 2.0b
<b>HDCP Compliance</b>	HDCP 2.2 and HDCP 1.4
<b>Video Bandwidth</b>	18 Gbps
<b>Video Resolutions</b>	up to 4K2K@50/60Hz(YUV4:4:4),4K2K@30Hz,1080P@120Hz, and 1080P 3D@60Hz
<b>Color Space</b>	RGB, YCbCr 4:4:4, YCbCr 4:2:2,
<b>Color Depth</b>	8-bit,10-bit,12-bit
<b>HDMI Audio Formats (Pass-through)</b>	LPCM 2/5.1/7.1CH, Dolby Digital, DTS 5.1, Dolby Digital+, Dolby TrueHD, DTS-HD Master Audio, Dolby Atmos, DTS:X
<b>Audio Formats (Audio Matrix)</b>	PCM2.0, 32K/44.1K/48K/88.2K/96K/192K,16/20/24bit
<b>Audio Volume (Audio Matrix)</b>	-20dB ~ 0dB
<b>L/R Audio Formats</b>	Analog Stereo 2CH
<b>Infrared</b>	20KHz ~ 60KHz
<b>ESD Protection</b>	Human body model — ±8kV (air-gap discharge) & ±4kV (contact discharge)
Connections	
Matrix Switcher	
<b>Inputs</b>	8x HDMI Type A [19-pin female] 10x IR In [3.5mm Stereo Mini-jack] 6x RS-232 [Phoenix jack] 1x Ethernet [RJ45] 1x RS-232 [DB9] 2x L/R Audio In [3.5mm Stereo Mini-jack] 2x Optical Audio In [Toslink] 2x Coaxial Audio In [RCA]
<b>Outputs</b>	2x HDMI Type A [19-pin female] 9x IR Out [3.5mm Stereo Mini-jack] 8x L/R Audio Out [3.5mm Stereo Mini-jack] 8x Coaxial Audio Out [RCA] 6x HDBaseT Out [RJ45]
HDBT Receiver	
<b>Inputs</b>	1x HDBaseT In [RJ45] 1x IR In [3.5mm Stereo Mini-jack] 1x Optical In [Toslink]
<b>Outputs</b>	1x HDMI Type A [19-pin female] 1x IR Out [3.5mm Stereo Mini-jack] 1x LAN [RJ45]
Mechanical	
<b>Housing</b>	Metal Enclosure
<b>Color</b>	Black

---

<b>Dimensions</b>	483mm [W] x 373mm [D] x 88.6mm [H]
<b>Weight</b>	6.7Kg
<b>Power Supply</b>	Input:AC100~240V 50/60Hz
<b>Power Consumption</b>	85W (Max)
<b>Operation Temperature</b>	32 - 104°F / 0 - 40°C
<b>Storage temperature</b>	-4 - 140°F / -20 - 60°C
<b>Relative Humidity</b>	20 - 90% RH (no condensation)

## 1.10 IR remote control

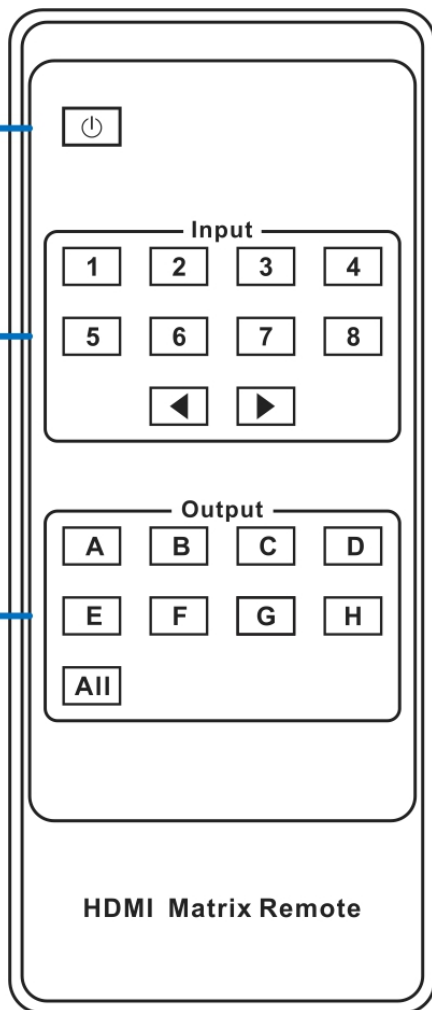

**1.11 Power on /Standby :** Power on/off this device.

**1.12 Input port selection area :** Press these buttons to select input 1-8. Press forward/backward button will cycle from input 1-8.

**1.13 Output port selection area :** Press these buttons to select output A-H, including ALL.

### 1.14 How to select Output and Input Port?

Q. OUTPUT-X select INPUT-Y:

A. Press OUTPUT-X (X means A to H of outputs, including ALL) Press INPUT-Y (Y means 1 to 8 of inputs)

## 1.15 IR control

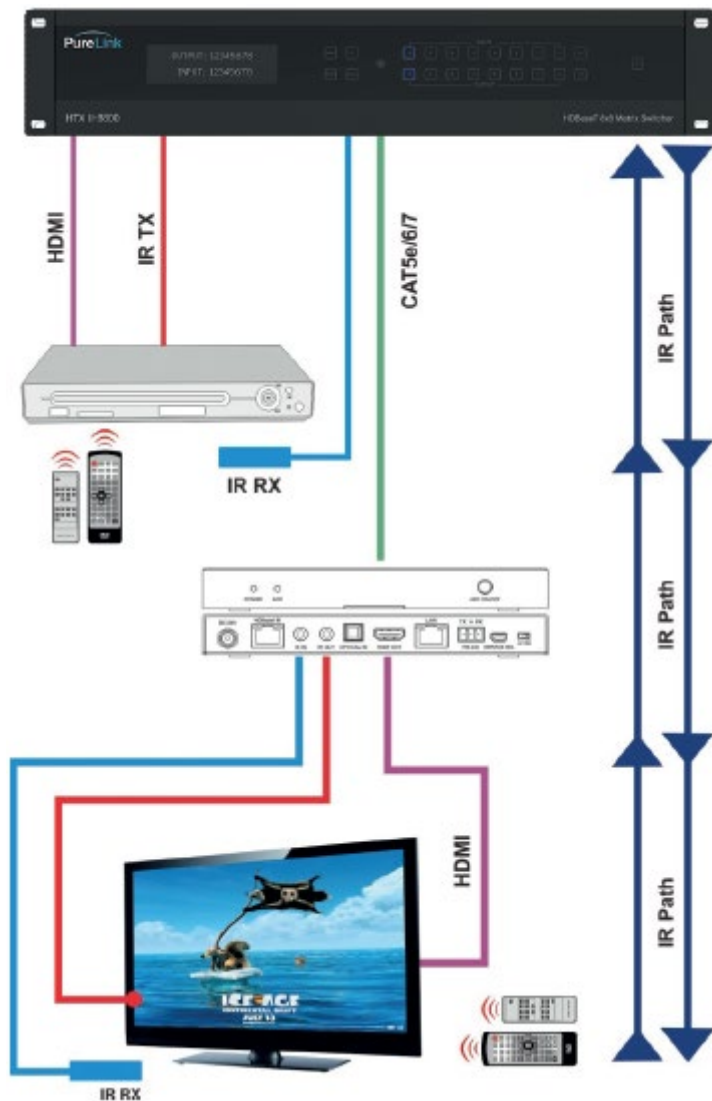

The matrix is not only a switcher and extender of multiple HDMI signals to HDMI receivers located remotely, it also passes IR control signal through the IR call-back system to the matrix and HDMI sources. Two-way IR Call –back between matrix, sources and displays from multiple locations. A key feature on matrix is discrete IR control of the matrix, sources and displays from any location –so inputs at the matrix end can be controlled at display location and displays can be controlled at matrix location. This is accomplished by placing a series of IR Emitters on devices to control and IR receiver at all locations you wish to control from to enable the IR signal to travel both ways via the single Cat5e/6/7 cable.

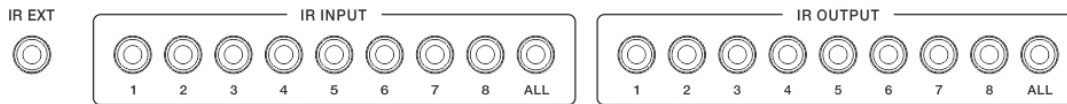

**1. At Matrix End:** Inset the 3.5mm jacks of the IR TX Emitters included in package into the IR TX Emitter ports at the rear of the matrix corresponding input. The IR signal is added to the HDMI of the input devices, for example, if the user is watching Blue-ray on input 1, the IR signal will be directed through the IR TX1 socket to control the device. As each IR TX port is allocated to an individual HDMI input port, if the user is unable to control device via IR, please check if the IR emitter and HDMI input ports match or not (Input1-TX1, Input2-TX2 etc.), and secondly, that the IR TX emitter sensors are firmly attached directly to the front of inputs and covering infrared sensor windows of the source devices. Some later adjustment may be needed to the location of the sensor to achieve the best performance - sometimes moving the sensor to different areas on the source can improve IR performance.

**Note:** Infrared receiving areas of devices can be located by shining a flashlight onto the front of the device – the sensor should be able to be seen through the plastic as a small, round object inside. Insert 3.5mm jacks of IR RX receivers into RX ports, making sure the receivers themselves are placed in clear view to receive an infrared signal from the remote handset used to control the display outputs.

**2. At Display End:** Insert the IR RX Receiver jack into the IR RX port of the display receiver balun, with the receivers themselves placed in clear view on or near the displays to receive an infrared signal from the remote handset used to control inputs. Insert the IR TX Emitter jack into the IR TX port of the display receiver balun, ensuring that the emitter sensor is securely attached to infrared sensor window of the display. Follow the same connection and position for all baluns/displays connected to the matrix.

**Note:** Misplaced or poorly secured IR Emitters and Receivers may result in intermittent IR control signals passed to and from the matrix. Check your placement and adjust if necessary.



**IR RECEIVER**

**IR BLASTER**

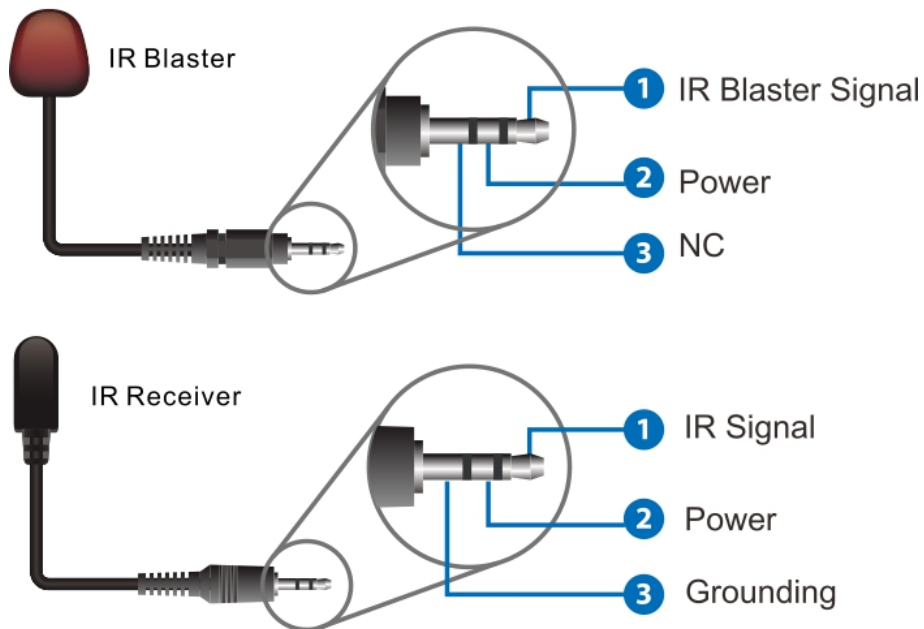

### 1.16 Cable Termination

- CATx (HDBaseT) cable
- RS-232 (HTX matrix switcher)
- LAN cable
- RS-232 (HTX extenders)

#### CATx (HDBaseT) Cable Termination

HTX series matrix switcher and extenders are designed with TIA/EIA-568-B Standard. Please ensure that each PIN layout of the cable is corresponding with the picture below before connecting the cable. Please note that CAT6 or above level cable enables to deliver better quality and longer distance.



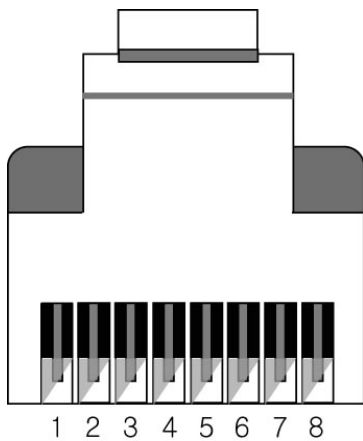

Pin	TIA/EIA-568B	Signal
	Wire color	Digital RGB
1	Orange/ White	TMDS Data2+
2	Orange	TMDS Data2-
3	Green/ White	TMDS Data1+
4	Blue	TMDS Data0+
5	Blue/ White	TMDS Data0-
6	Green	TMDS Data1-
7	Brown/ White	TMDS Clock+
8	Brown	TMDS Clock-

PureLink offers TotalWire CAT-X high performance cable for your CATx cable needs.

PureLink also offers extended warranty of HTX products when CX cables are used together.

For detail information, please contact [support@purelinkav.com](mailto:support@purelinkav.com).

## CX SERIES

### TOTALWIRE™ CAT-X High Performance Cable



<b>CX-010</b>	Certified CATx Cable with TotalWire Technology - 10m
<b>CX-020</b>	Certified CATx Cable with TotalWire Technology - 20m
<b>CX-030</b>	Certified CATx Cable with TotalWire Technology - 30m
<b>CX-040</b>	Certified CATx Cable with TotalWire Technology - 40m
<b>CX-050</b>	Certified CATx Cable with TotalWire Technology - 50m
<b>CX-070</b>	Certified CATx Cable with TotalWire Technology - 70m
<b>CX-100</b>	Certified CATx Cable with TotalWire Technology - 100m
<b>CX-1000</b>	Certified CATx Cable with TotalWire Technology - 1000' Reel

**RS-232 Cable Termination (for Control)**

**Note) Straight cable must be used for the communication with HTX series matrix switcher**

The following table shows the pinout of the RS-232 connector. DB9 cables are available with male-to-male, female-to-female, and male-to-female connectors. HTX series matrix switcher's RS-232 port uses a female DB9 connector and therefore requires a cable with a male connector.

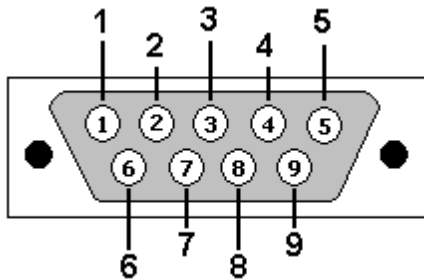

Pin	RS-232
1	Not used
2	Rx: Receive
3	Tx: Transmit
4	Not used
5	Ground
6	Not used
7	Not used
8	Not used
9	Not used

**LAN Cable Termination (for Control)**

The following table shows the pinout of the LAN connector. Note that in the pinout table, some transmit/receive functions (abbreviated as Tx/Rx) are different for straight-through cable and crossover LAN cable.

Straight-through Cable: for connection of HTX series matrix switcher to an Ethernet network

Crossover Cable : for direct connection between the PC or controller and the HTX series matrix switcher.

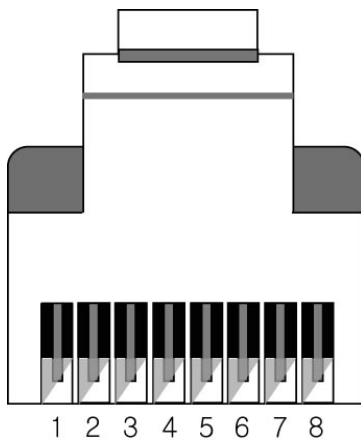

Pin	Crossover Cable	
	End 1 Wire Color	End 2 Wire Color
1	Orange/ White	Orange/ White
2	<b>Orange</b>	<b>Green</b>
3	Green/ White	Green/ White
4	Blue	Blue
5	Blue/ White	Blue/ White
6	<b>Green</b>	<b>Orange</b>
7	Brown/ White	Brown/ White
8	Brown	Brown

**RS-232 Cable Termination (for HTX receiver pass-thru)**

3-pin Phoenix connector is used for RS-232 communication between HTX matrix switcher and HTX receiver's connected device.

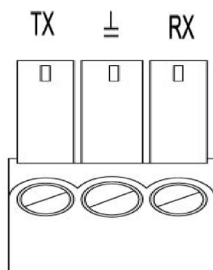

Pin	Straight-through Cable	
	End 1 Wire Color	End 2 Wire Color
1	Orange/ White	Orange/ White
2	Green	Green
3	Green/ White	Green/ White
4	Blue	Blue
5	Blue/ White	Blue/ White
6	Orange	Orange
7	Brown/ White	Brown/ White
8	Brown	Brown

Pin	RS-232	RS-422
1	Tx	Tx +
2	Ground	Ground
3	Rx	Rx +

\* Pinout from the left

**1.17 Installation Guidelines**

The following installation settings are recommended for optimal performance.

- Operational temperature should be 30° C or below
- Operational humidity should be 60% or below
- Operational environment should be dust-free and well ventilated
- Stabilized AC input power (AVR-based power supply) is highly advised

**1.18 Communication Settings (LAN and RS232)**

**Default RS232 communication parameters:**

Baud rate: 115200

Data bit: 8 bits

Stop bit: 1 bits

Parity: none

**Default LAN communication parameters:**

IP address: 192.168.0.100

Mac address: 0x00,0x15,0x09,0x22,0x4c,0x87

## Chapter 2. Communication Code Configuration

### 2.1 Control Programmer's Guide (Code Structure and Examples)

This section is designed for programmers who wish to create their own control programs using the command code. All PureLink digital matrix routers provide a simple character stream control used by external control devices attached to a PureLink device. Command codes are used primarily for control, during system installation and setup, and for diagnostic purposes.

### 2.2 Overview

Command code is a set of alphanumeric characters that combine to form control commands. Command code strings are entered into a terminal emulation program (such as windows HyperTerminal) running on an external control device. The control device (PC, third-party controller) sends the commands to the system. Control devices must be able to send and receive ASCII or HEXA code via an RS-232 or Ethernet port.

### 2.3 Command Code Formats

A command code is a series of command characters and numbers used to send commands to the system. Commands include basic formulas for creating and disconnecting switches, as well as for verifying the status of switches.

In a command code, each character is either general command (e.g., C for connect) or an identifier that indicates what the following number designates (e.g., "O" and the number following it designate an "output number"). The command code \*999CI01O01! Can be interpreted as follows: (\*) Starting the command code (999) Router ID is 999 (C) Create connection on (I01) Input 01 to (O01) Output 01 (!) take the command. For a complete list of command characters and their functions, see pages 16 -

Ack value (Acknowledge value: Response from Pure Link device) will be echoed back to the terminal screen as the unit accepts them. When a command is successfully executed, all of the characters appear containing the character "s" which stands for status. For example,

Ex 1) Command (Connect Input 1 to Output 1)

```
*999CI01O01! ↵
```

Ack value

```
*999sC I01O01!
```

Ex 2) Command (Check Input connection status on Output 3)

```
*999?O03! ↵
```

Ack Value

```
*999s? I03O03!
```

## 2.4 General Rules for Command Codes

The commands are coded in ASCII and HEXA. Please refer to Table 2.1 on pg. 17 for detailed descriptions of keys and functions. A basic command code setup is shown below;

Ex) \*999CI01O01!↵

Start (\*) + Router ID (999) + Command (C) + Input number (I01) + Output number (O01) + End (!) + Enter (↵)

- ▶ A command line allows execution of only one command. Multiple commands require execution of multiple strings; one command per string.
- ▶ All s begin with \* (Start) byte.
- ▶ All s end with ! (End) byte.
- ▶ All s will be executed when ↵ (Enter) is entered.
- ▶ The correct Router ID must be entered in a command code. Systems will not react to the command if a wrong Router ID is entered. The Factory Default Router ID is set to 999 and the universal Router ID is 999. Systems will react to the command whenever universal Router ID is entered in command code.
- ▶ Command codes typically are not case-sensitive.
- ▶ To specify multiple inputs and outputs, enter a “,” (Comma) between numbers.  
(Ex., \*999CI01O01,02,03! ↵: Connects Input 01 to Output 01, 02, and 03)
- ▶ Use - (Hyphen) for range connection.  
(EX., \*999CI01O01-04! ↵: Connects Input 01 to Output 01,02,03, and 04)

**Table 2.1 Command Codes Characters Table**

The table below shows command code characters (keys), which are used to generate control commands, their functions, and short function descriptions.

Key		Function	Description and Example	Byte
HEX	ASCII			
0x2A	*	Start the command	Header Code	1
0x21	!	End the command	Tail Code	1
	↵	Execute the command	Execute the command	
0x43 0x63	C C	Connect	Initiates a Connect (switch) command for Video; this must precede input and output specification	1
0x3F	?	Status	Status command; this must precede input and output specification	1
0x44 0x64	D D	Disconnect	Disconnect command for both Video and Audio; this must precede input and output specification	1
	,	Space	Separates the numbers within entries that contain multiple numbers	1
	-	Range	Specifies a range of numbers in entries containing multiple numbers	1
	?version	Firmware version check	Firmware version check command; *255?version! ↵	

## 2.5 Command Ack (Acknowledge) Value Response

When command codes are entered into a terminal emulation program (such as HyperTerminal) and are accepted by the system, they respond back to the terminal screen one at a time, as noted below in the table. The complete command has executed successfully when all of the entered characters including “s” which stands for status, appear. If a command character is not accepted, a different character than the one entered appears and all or part of the command has not been executed.

### Ack (Acknowledge) Value Response Table

The following table shows ack value response characters along with their descriptions and meanings, which may appear instead of the initially entered character or number. If these characters appear, all or part of the command has not been executed.

**Table 3.2 Descriptions of Acknowledge (ACK) Signals**

Ack value	Description
Input 1 is not connected	No information in each channel.
Command Code Error	Indicates that system has rejected all or part of the command

Router ID Error	Indicates that the wrong ID number was entered
-----------------	--

### Command Code Ack Value Examples

Command Code Entered	Ack Value as appears in the control program	Explanation of Result
*999CI01O01! ↵	*255sC I01O01 !	The command was successfully executed
*999CO01! ↵	Command Code Error	The command was not executed because the input number was not included
*999CI01O01 ↵	Command Code Error	The command was not executed because “!” (End) was not included
*300CI01O01! ↵	Router ID Error	The command was not executed because the actual Router ID and entered Router ID did not match

## 2.6 Connecting Switches

A switch is an active connection between an input (source) signal and one or more output (display) devices. The signals connected in a switch command are either individual signals or groups of signals coming through the connectors on the rear of the unit.

The “C” key initiates a Connect command for routing a switch. The characters and numbers that follow the “C” command tell the system, which inputs and outputs to connect. The last character “!” is found at the end of a command code which tells the system to execute the command.

For example, the command code \*999CI01O01! ↵

can be interpreted as follows: (\*) Starting the command code (999) Router ID is 999 (C) Create connection on (I01) Input 01 to (O01) Output 01 (!) take the command. For a complete list of command characters and their functions, see examples below.

To connect a switch:

1. Enter the Connect command below. Replace the “#”s with the input and output number(s).

\*999CI#O#! ↵

Examples (Connect) :

Command Codes	Action
*999CI01O01! ↵	Connect Input 1 to Output 1
*999CI01O04,I04O02! ↵	Connect Input 1 to Output 4 and Input 4 to Output 2
*999CI01O01,I02O02,I03O03! ↵	Connect Input 1 to Output 1, Input 2 to Output 2, and Input 3 to Output 3
*999CI01O01,02,03! ↵	Connect Input 1 to Output 1, 2, and 3



*999CI01O01-04! ↵	Connect Input 1 to Output 1, 2, 3, and 4
*999PTP! ↵	Connect Input 1 to Output 1, Input 2 to Output 2, Input 3 to Output 3 and Input 4 to Output 4

## 2.7 Disconnecting Switches

The characters and numbers in a Disconnect command tell the system which input or output to disconnect. The “D” key initiates a Disconnect command for routing a switch. The characters and numbers that follow the “D” command tell the system that inputs and outputs to disconnect. The last character “!” is found at the end of the Command code, which tells the system to execute the command.

For example, the command code

\*999DI01O00! ↵

It can be interpreted as follows: (\*) Starting the command code (999) Router ID is 999 (D) Disconnect on (I01) Input 01 to (O00) Output 00 (!) take the command. For a complete list of command characters and their functions, see the command list below

1. Enter the Disconnect command below. Replace the “#”s with the input and output number(s).

\*999DI#O#! ↵

Examples (Disconnect) :

Command Codes	Action
*999DI01O00! ↵	Disconnect Input 1 to no Output (00)
*999DI00O03,04! ↵	Disconnects Outputs 3, and 4
*999DI00O03-04! ↵	Disconnects output 3, and 4
*999DALLIO! ↵	Disconnects all inputs and outputs

**EDID Setting**

\*999EDIDI01E3! ↵

: write E3 EDID (1080p, HD audio) to input # 1

**List of EDID**

E1	1080p, Stereo Audio 2.0	E2	1080p, Dolby/DTS 5.1	E3	1080p, HD Audio 7.1
E4	1080i, Stereo Audio 2.0	E5	1080i, Dolby/DTS 5.1	E6	1080i, HD Audio 7.1
E7	3D, Stereo Audio 2.0	E8	3D, Dolby/DTS 5.1	E9	3D, HD Audio 7.1
E10	4K2K30_444, Stereo Audio 2.0	E11	4K2K30_444, Dolby/DTS 5.1	E12	4K2K30_444, HD Audio 7.1
E13	4K2K60_420, Stereo Audio 2.0	E14	4K2K60_420, Dolby/DTS 5.1	E15	4K2K60_420, HD Audio 7.1
E16	4K2K60_444, Stereo Audio 2.0	E17	4K2K60_444, Dolby/DTS 5.1	E18	4K2K60_444, HD Audio 7.1
E19	Copy HDMI OUT A	E20	Copy HDMI OUT B	E21	Copy HDBaseT OUT C
E22	Copy HDBaseT OUT D	E23	Copy HDBaseT OUT E	E23	Copy HDBaseT OUT F
E23	Copy HDBaseT OUT G	E23	Copy HDBaseT OUT H		

**Beep On**

\*999BeepON! ↵

**Beep Off**

\*999BeepOFF! ↵

**Front panel buttons Lock On**

\*999lockon! ↵

**Front panel buttons Lock Off**

\*999lockoff! ↵

**Power on**

\*999poweron! ↵

**Power off**

\*999poweroff! ↵

**Factory setting restore**

\*999restore! ↵

**Reboot**

\*999reboot! ↵

## 2.8 Status Check

A connection status can be checked to confirm that the switch has been correctly executed or to confirm correct routing to multiple outputs. The characters and numbers in a status command tell the system which input or output to check.

1. Enter the Connection status check command below. Replace the “#”s with the input and output number(s).

\*999?I#!↵ or \*255?O#!↵

Examples:

Command Codes	Action
*999?I01!↵	Check Output connection status on Input 1
*999?O04!↵	Check Input connection status on Output 4
*999?ALLIO!↵	Check all Input and Output connection status

### Input EDID status

\*999?EDIDI01!↵

I01 = input 1   I02 = input 2   I03 = input 3   I04 = input 4

### Firmware version check

\*999?version!↵

## Chapter 3. Additional Information

### 3.1 Manufacturer's Warranty (3-Years)

PureLink warrants this HTX series matrix switcher to be free from defects in workmanship and materials, under normal use and service, for a period of three (3) year from the date of purchase from PureLink or its authorized resellers.

If the product does not operate as warranted during the applicable warranty period, PureLink shall, at its option and expense, execute one of the following as necessary:

1. Repair the defective product or part
2. Deliver to customer and equivalent product or part to replace the defective item
3. Refund to customer the purchase price paid for the defective product

All products that are replaced become the property of PureLink. Replacement products may be new or reconditioned. Repaired or replacement products or parts come with a 90-day warranty or the remainder of the warranty period. Dtrovision shall not be responsible for any software, firmware, information, or memory data loss of contained in, stored on, or integrated with any products returned to Dtrovision for repair under warranty.

### 3.2 Customer Service

Any customer service inquiries can be submitted electronically through the Q&A form on our website ([www.purelinkav.com](http://www.purelinkav.com)).

For immediate assistance please contact us at (201) 488-3232 to reach our customer care or tech support team.